

FEATURES

- 4 channels for R L C loads and for dimmable CFL and LED lamps
- Automatic detection of R L C load type
- Automatic frequency detection
- dimming pattern selection for CFL and LED lamps
- Optional manual dimming control
- Total data saving on KNX bus failure
- Integrated KNX BCU (TP1-256)
- Dimensions 67 x 90 x 79 mm (4.5 DIN units)
- DIN rail mounting according to IEC 60715 TH35, with fixing clamp
- Conformity with the CE, RCM directives (marks on the right side)

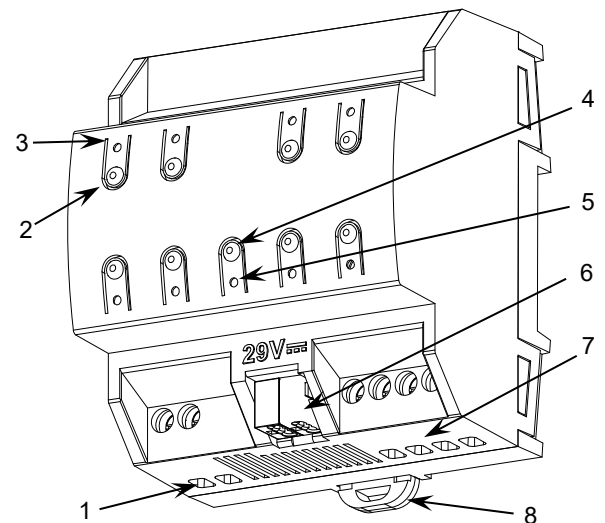

Figure 1: NarrowDIM X4

1. Power supply input	2. Output control button	3. Output status LED	4. Programming/Test button
5. Programming/Test LED	6. KNX connector	7. Output channels	8. Fixing clamp

Programming/Test button: short press to set programming mode. If this button is held while plugging the device into the KNX bus, it enters the safe mode. If this button is held for more than 3 seconds, the device enters the test mode.

Programming/Test LED: programming mode indicator (red). When the device enters the safe mode, it blinks (red) every half second. The test mode is indicated by the green color. During the start-up (reset or after KNX bus failure) and if the device is not in safe mode, it emits a red flash.

GENERAL SPECIFICATIONS

CONCEPT		DESCRIPTION		
Type of device		Electric operation control device		
KNX supply	Voltage (typical)	29 VDC SELV		
	Voltage range	21-31 VDC		
	Maximum consumption	Voltage	mA	mW
		29 VDC (typical)	13.3	385.7
24 VDC ¹	20	480		
Connection type		Typical TP1 bus connector for 0.8 mm Ø rigid cable		
External power supply		110-230 VAC 50/60 Hz		
Operation temperature		0 .. +40 °C		
Storage temperature		-20 .. +55 °C		
Operation humidity		5 .. 95%		
Storage humidity		5 .. 95%		
Complementary characteristics		Class B		
Protection class		II		
Operation type		Continuous operation		
Device action type		Type 1		
Electrical stress period		Long		
Degree of protection		IP20, clean environment		
Installation		Independent device to be mounted inside electrical panels with DIN rail (IEC 60715)		
Minimum clearances		Not required		
Response on KNX bus failure		Data saving according to parameterization		
Response on KNX bus restart		Data recovery according to parameterization		
Operation indicator		The programming LED indicates programming mode (red) and test mode (green). Each output LED indicates its status (fixed = active output; flashing = overload or short-circuit error).		
Weight		238 g		
PCB CTI index		175 V		
Housing material		PC FR V0 halogen free		

¹ Maximum consumption in the worst-case scenario (KNX Fan-In model).

OUTPUTS SPECIFICATIONS AND CONNECTIONS			
CONCEPT	DESCRIPTION		
Number of outputs	4		
Output type	Solid state switching device		
Short-circuit protection	YES		
Overload protection	YES		
Connection method	Screw terminal block (0.5 Nm max.)		
Cable cross-section	1.5-4 mm ² (IEC) / 26-10 AWG (UL)		
LOADS AND ALLOWED POWER (@ 35 °C ambient temperature around the device)			
	230 VAC		
	110 VAC		
RLC	Individual channel	Up to 210 W	Up to 160 W
	Double channel ²	Up to 400 W	Up to 300 W
	Quadruple channel ²	Up to 750 W	Up to 600 W
CFL and LED ¹	Individual channel	Up to 210 W	Up to 160 W
	Double channel ²	Up to 400 W	Up to 300 W
	Quadruple channel ²	Up to 750 W	Up to 600 W

¹ For leading edge, the maximum load could change depending on the load type. Please refer to the link https://zennio.com/documents/technical_note_diminbox-dx_list_process_en.

Also, for load characterization proces https://www.zennio.com/documents/technical_note_diminbox-dx2_tests_en

² The load must be connected like is shown in the Figure 2, making a parameterization consistent with the connexion.

EXTERNAL POWER SUPPLY SPECIFICATIONS AND CONNECTIONS		
CONCEPT	DESCRIPTION	
Power supply protection fuse	Voltage	250 V
	Current	10 A
	Response type	T (time-lag)
Connection method	Screw terminal block (0.5 Nm max.)	
Cable cross-section	1.5-4 mm ² (IEC) / 26-10 AWG (UL)	

WIRING DIAGRAMS

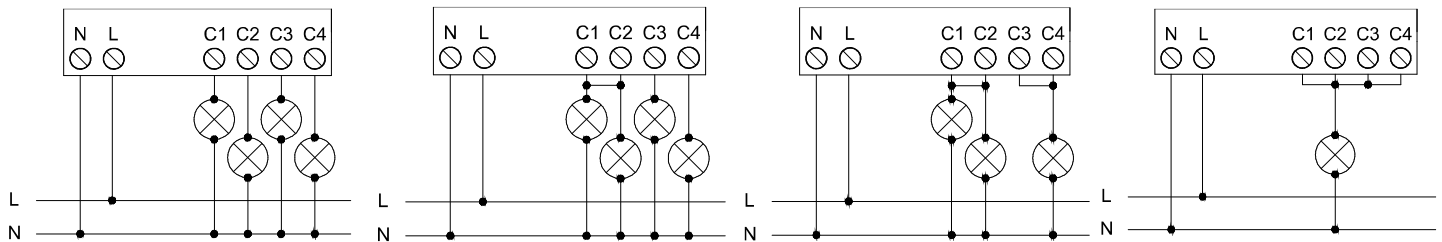



Figure 2: Wiring example (from left to right):

- 4 individual channels,
- 1 double channel + 2 individual channels,
- 2 double channels,
- 1 quadruple channel

SAFETY INSTRUCTIONS AND ADDITIONAL NOTES

- Installation should only be performed by qualified professionals according to the laws and regulations applicable in each country.
- Do not connect the mains voltage nor any other external voltage to any point of the KNX bus; it would represent a risk for the entire KNX system. The facility must have enough insulation between the mains (or auxiliary) voltage and the KNX bus or the wires of other accessories, in case of being installed.
- The facility must be equipped with a device that ensures the omnipolar sectioning. Installation of a 10 A mini-circuit-breaker is recommended. To prevent accidents, it must remain open in case of manipulation of the device.
- The device has a short-circuit protection fuse that, in case of activation, should only be rearmed or replaced by the Zennio technical service.
- Once the device is installed (in the panel or box), it must not be accessible from outside.
- Keep the device away from water (condensation over the device included) and do not cover it with clothes, paper or any other material while in use.
-  The WEEE logo means that this device contains electronic parts and it must be properly disposed of by following the instructions at <https://www.zennio.com/en/legal/weee-regulation>.
- This device contains software subject to specific licences. For details, please refer to <https://zennio.com/licenses>.

SUPPORTED LOADS

- R = Resistive
- L = Inductive
- C = Capacitive
- CFL = Dimmable Compact Fluorescent Lamps
- LED = Dimmable LED lamps

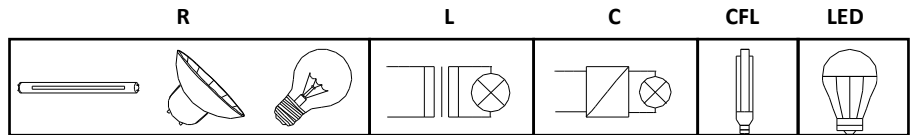
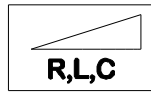

Please, make sure that the loads used are dimmable.

LOAD COMBINATION

- In case of combining resistive (R) with inductive (L) loads, the resistive loads must not exceed the 50% of the total power.
- In case of combining resistive (R) with capacitive (C) loads, the resistive loads must not exceed the 50% of the total power.
- **Combination of capacitive loads with inductive loads in the same channel is NOT ALLOWED.**
- Do not combine in the same channel CFL or LED lamps with R L C loads.
- It is not advisable to combine different models of CFL lamps, LED lamps or transformers in the same channel since correct operation can be affected.

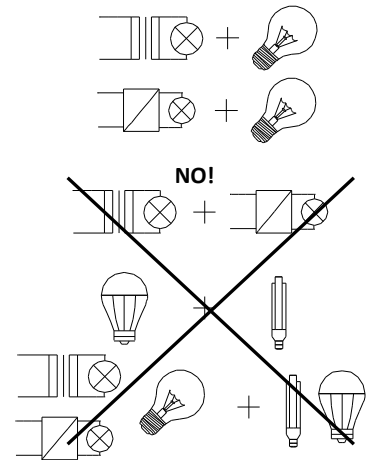

OVERHEATING PROTECTION

- When the ambient temperature is too high the universal dimmer actuator will regulate itself, at a maximum of 20%.
- Once the ambient temperature decreases, the dimmer will resume normal operation. Please, refer to user manual.

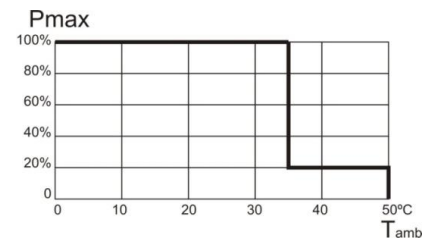

Attaching NarrowDIM X4 to DIN rail:

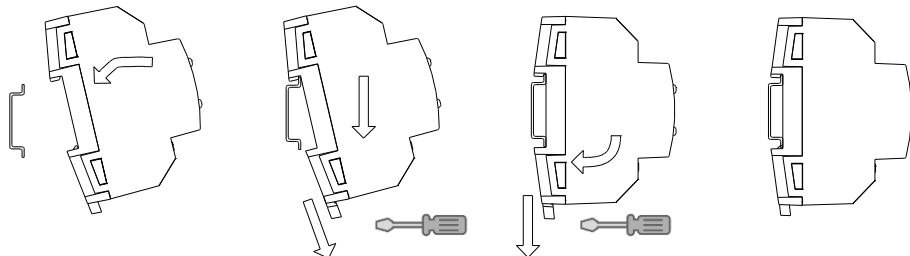

Removing NarrowDIM X4 from DIN rail:

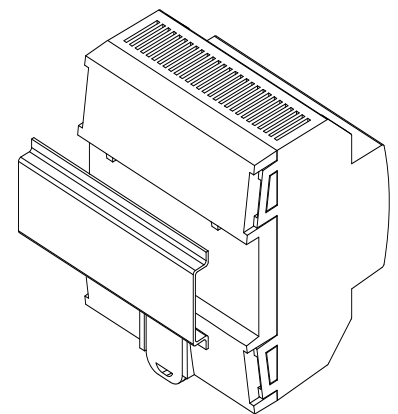
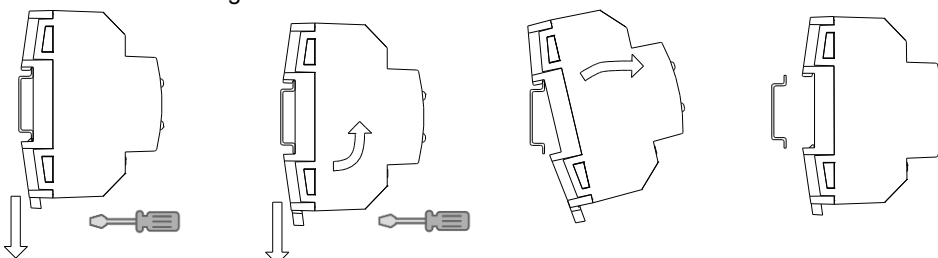

Figure 3: Mounting NarrowDIM X4 on DIN rail

ERROR NOTIFICATIONS		
ERROR	LEDS DESCRIPTION	VISUAL NOTIFICATION
Short circuit	The two LEDs of the channel alternate every 0.25 second. When the output is locked, the programming LED blinks in blue.	
Voltage Surge	The two LEDs of the channel blink simultaneously every 0.25 second. When the output is locked, the programming LED lights in blue	
Overheating	The LEDs of all the channels blink every second.	
Supply Voltage Failure	One LED of each channel blinks every second.	
Anomalous Frequency	All the LEDs of each channel blink (during 1 second) sequentially	
Parameterization Error	One LED of the channel blinks every second while the other LED blinks every 0.25 second.	