

FEATURES

- 3 fan speed control outputs
- 2 configurable outputs as open/close valves or a 3-point valve
- 2 configurable outputs as a second 3-point valve, individual outputs or a shutter channel*
- Possibility of controlling blinds/shutters with 2 or 3 dry contacts
- Supports KNX Data Secure
- 6 analog/digital inputs
- Manual output operation with push button and LED status indicator
- Logic functions
- Output timing functionality
- Total data saving on KNX bus failure
- Integrated KNX BCU (TP1-256)
- Dimensions 67 x 90 x 79 mm (4.5 DIN units)
- DIN rail mounting according to IEC 60715 TH35, with fixing clamp
- Possibility of connecting different phases in adjacent outputs
- Conformity with the CE, RCM directives (marks on the right side)

* Suitable for capacitive loads, maximum 140 µF

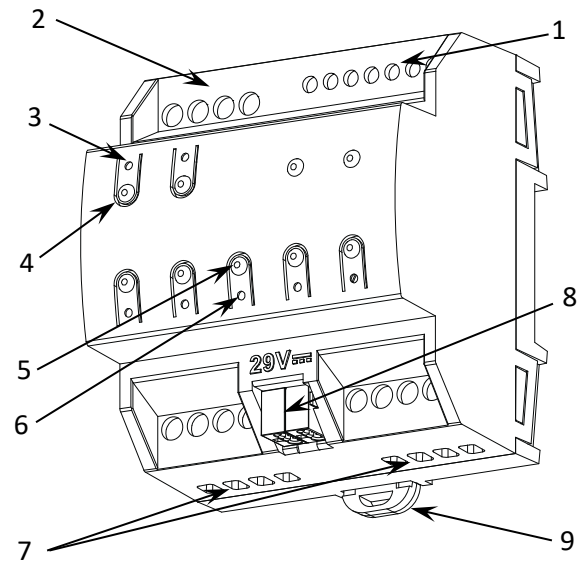

Figure 1: MAXinBOX Hospitality v3

1. Analog/Digital inputs	2. Fan outputs	3. Output status LED	4. Output control button	5. Programming/Test button
6. Programming/Test LED	7. Valve/Individual/Shutter outputs	8. KNX connector	9. Fixing clamp	

Programming/Test button: short press to set programming mode. If this button is held while plugging the device into the KNX bus, it enters the safe mode. If this button is held for more than 3 seconds, the device enters the test mode. In order to perform a KNX Secure factory reset, while the device is in safe mode, press the button for 10 seconds until the programming LED changes its state.

Programming/Test LED: programming mode indicator (red). When the device enters the safe mode, it blinks (red) every half second. The test mode is indicated by the green color. During the start-up (reset or after KNX bus failure) and if the device is not in safe mode, it starts a blue blinking sequence.

GENERAL SPECIFICATIONS

CONCEPT		DESCRIPTION		
Type of device		Electric operation control device		
KNX supply	Voltage (typical)	29 VDC SELV		
	Voltage range	21-31 VDC		
	Maximum consumption	Voltage	mA	mW
		29 VDC (typical)	5.6	162.4
24 VDC ¹	10	240		
Connection type		Typical TP1 bus connector for 0.8 mm Ø rigid cable		
External power supply		Not required		
Operation temperature		0 .. +55 °C		
Storage temperature		-20 .. +55 °C		
Operation humidity		5 .. 95%		
Storage humidity		5 .. 95%		
Protection class / Overvoltage category		- / III (4000 V)		
Operation type		Continuous operation		
Device action type		Type 1		
Electrical stress period		Long		
Complementary characteristics		Class B		
Degree of protection / Pollution degree		IP20 / 2 (clean environment)		
Installation		Independent device to be mounted inside electrical panels with DIN rail (IEC 60715)		
Minimum clearances		Not required		
Response on KNX bus failure		Data saving according to parameterization		
Response on KNX bus restart		Data recovery according to parameterization		
Operation indicator		The programming LED indicates programming mode (red) and test mode (green). Each output LED indicates its status (fixed = active output; flashing = error in the output).		
Weight		246 g		
PCB CTI index		175 V		
Housing material / Ball pressure test temperature		PC FR V0 halogen free / 75 °C (housing) - 125 °C (connectors)		

¹ Maximum consumption in the worst-case scenario (KNX Fan-In model).

CONCEPT		DESCRIPTION
Output type / Disconnection type		Potential-free outputs through bistable relays / micro-interruption
Outputs per common	Individual/Valve	1
	Fan outputs	3
Different phases connection (valve and individual outputs)		Possibility of connecting different phases. It is not allowed to connect power supplies of different order, SELV with NO SELV, in the same block.
Maximum response time		10 ms
Connection method		Screw terminal block (0.5 Nm max.)
Cable cross-section		1.5-4 mm ² (IEC) / 26-10 AWG (UL)
F1-3/V1-2 OUTPUTS		
Rated current per output		AC 8(4) A @ 250 VAC (2000VA) DC 5 A @ 30 VDC (150W)
Maximum load per output	Resistive	2000 W
	Inductive	1000 VA
Mechanical lifetime (min. cycles)		1 000 000
O1-2 OUTPUTS		
Rated current per output		AC 16(6) A @ 250 VAC (4000 VA) DC 7 A @ 30 VDC (210 W)
Maximum load per output	Resistive	4000 W
	Inductive	1500 VA
Maximum inrush current		800 A/200 μs 165 A/20 ms
Mechanical lifetime (min. cycles)		3 000 000
Electrical lifetime (min. cycles) ¹		100000 @ 8 A / 25000 @ 16 A (VAC)

¹ Lifetime values could change depending on the load type.

CONCEPT		DESCRIPTION
Number of inputs		6
Inputs per common		6
Operation voltage		3.3 VDC in the common
Operation current		1 mA @ 3.3 VDC (per input)
Switching type		Dry voltage contacts between input and common
Connection method		Screw terminal block (0.5 Nm max.)
Cable cross-section		1-2.5 mm ² (IEC) / 26-12 AWG (UL)
Maximum cable length		30 m
NTC accuracy (@ 25 °C) ²		±0.5 °C
Temperature resolution		0.1 °C
Maximum response time		10 ms

² For Zennio temperature probes.

INPUTS CONNECTION

Any combination of the following accessories is allowed in the inputs:

Temperature Probe**

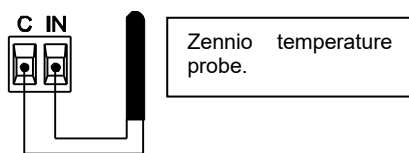

Motion Sensor

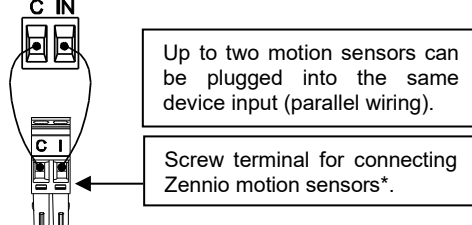

Switch/Sensor/ Push button

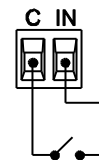

* In case of using ZN110-DETEC-P sensor, its micro switch number 2 must be in **Type B position**.

** Zennio temperature probe or any NTC with known resistance values at three points in the range [-55, 150 °C].

⚠ Commons of different devices must not be connected together.

WIRING DIAGRAMS

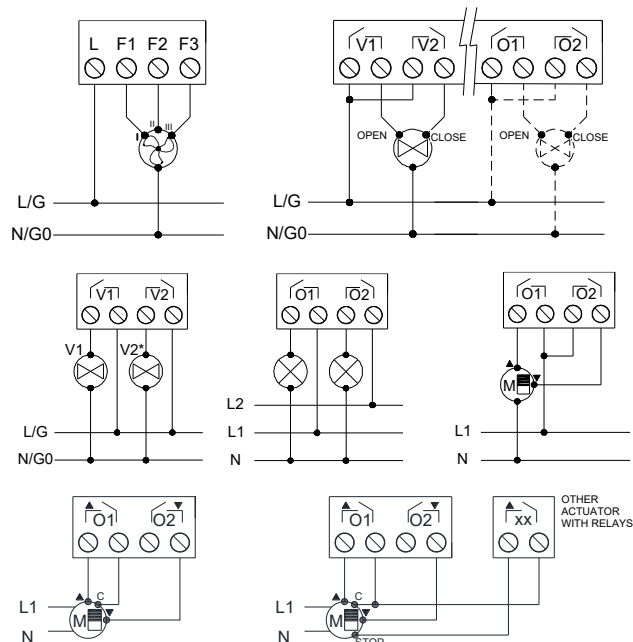

Figure 2: Wiring example (from left to right and from top to bottom): Three-speed fan, 1 or 2 three-point valves, 2 open/close valves, 2 loads connected to different phases, shutter channel, shutter with 2 dry contacts and shutter with 3 dry contacts

* In case of 2-pipe fan coil (only one open/close valve), V2 can be used as an individual output (up to 4A and not capacitive load).

For 4-pipe fan coil, the cooling valve should always be connected at the left side and the heating valve at the right side. Before the start-up of the device it must be assured that the valve is completely closed.

⚠ In order to ensure the expected status of the relays, please check that the device is connected to the KNX bus before energizing the power circuit.

Attaching MAXinBOX Hospitality v3 to DIN rail:

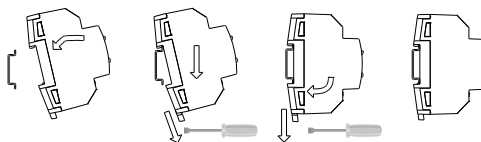

Removing MAXinBOX Hospitality v3 from DIN rail:

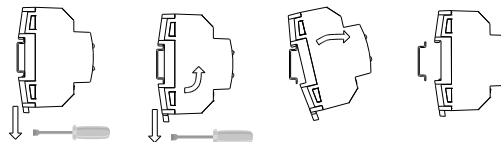

SAFETY INSTRUCTIONS AND ADDITIONAL NOTES

- Installation should only be performed by qualified professionals according to the laws and regulations applicable in each country.
- Do not connect the mains voltage nor any other external voltage to any point of the KNX bus; it would represent a risk for the entire KNX system. The facility must have enough insulation between the mains (or auxiliary) voltage and the KNX bus or the wires of other accessories, in case of being installed.
- The home automation facility must be equipped with a device that ensures the omnipolar sectioning. Installation of a 16 A mini-circuit-breaker is recommended. To prevent accidents, it must remain open in case of manipulation of the device.
- Once the device is installed (in the panel or box), it must not be accessible from outside.
- Keep the device away from water (condensation over the device included) and do not cover it with clothes, paper or any other material while in use.
- The WEEE logo means that this device contains electronic parts and it must be properly disposed of by following the instructions at <https://www.zennio.com/en/legal/wEEE-regulation>.
- This device contains software subject to specific licences. For details, please refer to <https://zennio.com/licenses>.